



# SM7B

## Cardioid Dynamic Vocal Microphone

Shure SM7B dynamic microphone user guide. Includes information on the frequency response, how to mount, preamp recommendations, and specs.

Version: 2.5 (2024-D)

# Table of Contents

<b>SM7B Cardioid Dynamic Vocal Microphone</b>	<b>3</b>	<b>Adjust the Frequency Response Switches</b>	<b>7</b>
		Additional Tips	9
<b>General Description</b>	<b>3</b>	<b>Additional Resources</b>	<b>9</b>
<b>Microphone Placement</b>	<b>3</b>	<b>Specifications</b>	<b>9</b>
Windscreen	4	<b>Accessories</b>	<b>11</b>
<b>Mounting Instructions</b>	<b>4</b>	Furnished Accessories	12
<b>Preamplifier Use</b>	<b>6</b>	Optional Accessories	12
		Replacement Parts	12
<b>Install or Remove the Stand Adapter</b>	<b>7</b>	<b>Certifications</b>	<b>12</b>

---

# SM7B

## Cardioid Dynamic Vocal Microphone

---

### General Description

The Model SM7B dynamic microphone has a smooth, flat, wide-range frequency response appropriate for music and speech in all professional audio applications. It features excellent shielding against electromagnetic hum generated by computer monitors, neon lights, and other electrical devices. In addition to its standard windscreens, it also includes the A7WS windscreen for close-talk applications.

The SM7B is an outstanding choice for the following applications:

- Recording Studio—Instrumental and Vocal
- Location Recording
- Motion Picture and Television Scoring
- Television, Talk Shows, and News Desks
- Radio Announcing and Production
- Narration

---

### Microphone Placement

Speak directly into the mic, 1 to 6 inches (2.54 to 15 cm) away to block off-axis noise. For a warmer bass response, move closer to the microphone. For less bass, move the microphone away from you.

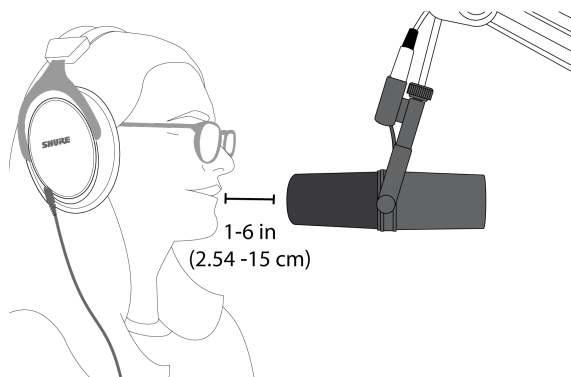

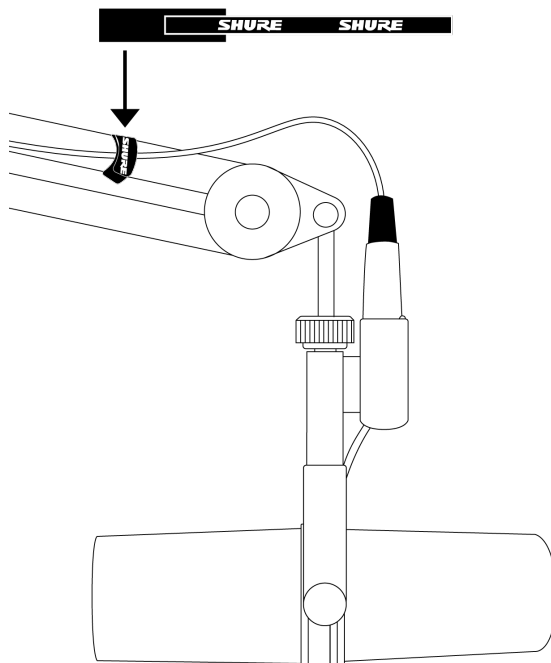

#### Velcro Cable Tie

*Use the enclosed velcro tie to secure the cable.*

## Windscreen

Use the standard windscreen for general voice and instrumental applications.

When you speak, you may hear vocal pops from some consonant sounds (known as plosives). To prevent more plosive sounds and wind noise, you can use the larger A7WS windscreen.

## Mounting Instructions

The default setup for the SM7B is for a boom mount. To set up the SM7B for a microphone stand:

1. Remove tightening nuts on the sides.
2. Remove the fitted washers, the lock washers, the outer brass washers, and the brass sleeves.
3. Slide the bracket off the microphone. Be careful not to lose the washers still on the microphone.
4. Invert and rotate the bracket. Slide it back onto the bolts over the brass and plastic washers still on the microphone.  
The bracket should fit so the XLR connector faces the rear of the microphone and the Shure logo on the back of the microphone is right-side up.
5. Replace the brass sleeves. Be sure they are seated properly within the inner washers.
6. Replace the outer brass washers, the lock washers, and the fitted washers.
7. Replace the tightening nuts and tighten the microphone at the desired angle.

**Note:** If the tightening nuts do not hold the microphone in place, you may need to re-position the brass sleeves and the washers.

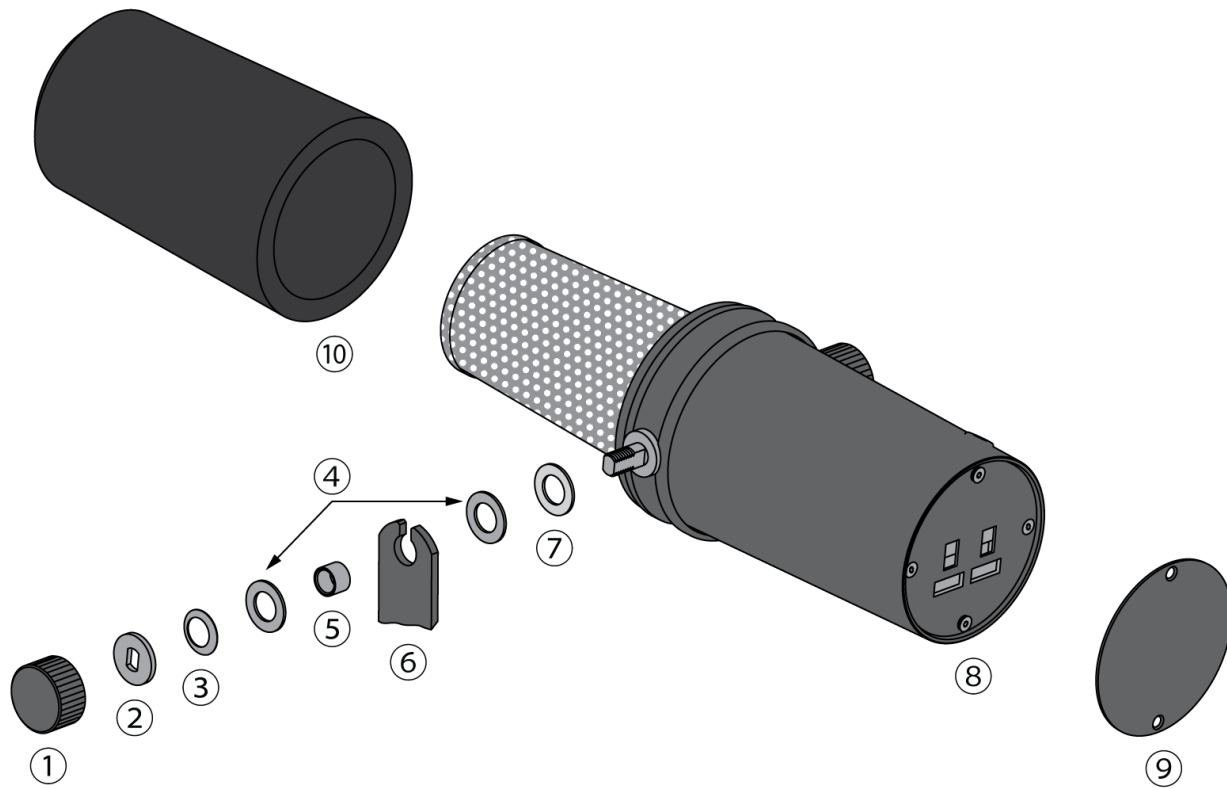

Mounting Assembly - Exploded View

- ① Tightening nut
- ② Fitted washer
- ③ Lock washer
- ④ Brass washers
- ⑤ Brass sleeve
- ⑥ Mounting bracket
- ⑦ Plastic washer
- ⑧ Response switches
- ⑨ Switch cover
- ⑩ Windscreen

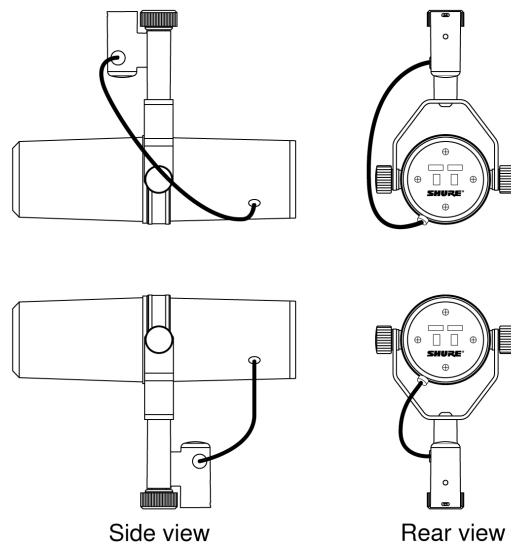

### Boom and Microphone Stand Mounting Configuration

## Preamplifier Use

The SM7B has a sensitivity rating at  $-59$  dB and requires more gain than what most entry-level or mid-tier preamplifiers can deliver. Use an inline boost amplifier or stronger preamp if your preamp does not have more than  $60$  dB of gain.

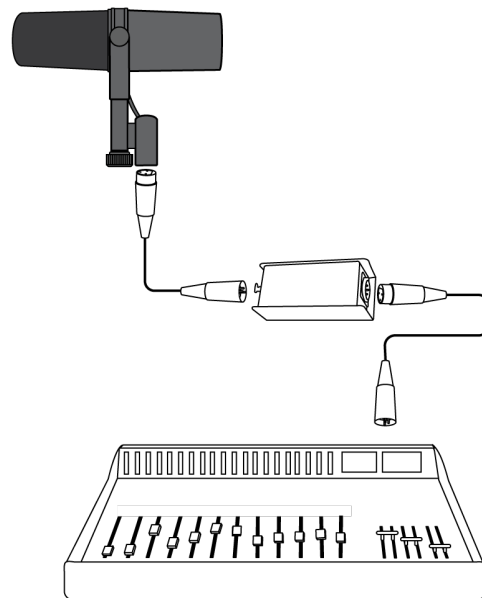

---

## Install or Remove the Stand Adapter

To mount the microphone on a 3/8 in. stand, insert the included brass stand adapter and tighten it with a coin or screwdriver.

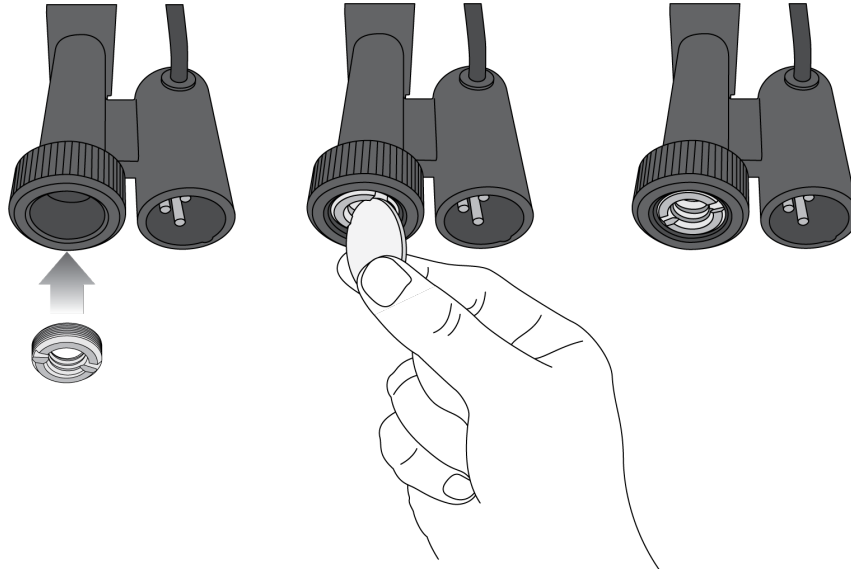

**Important:** Make sure that the slots on the adapter face outward.

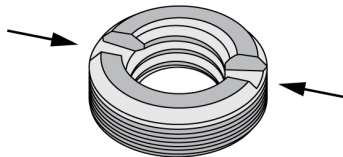

---

## Adjust the Frequency Response Switches

You can use a pen, pencil, or screwdriver to move the switches on the back panel. This adjusts the frequency response.

**Note:** You can change the switch settings while the mic is in use or plugged in.



### Flat Response

**Flat response:** This default setting works for most applications.

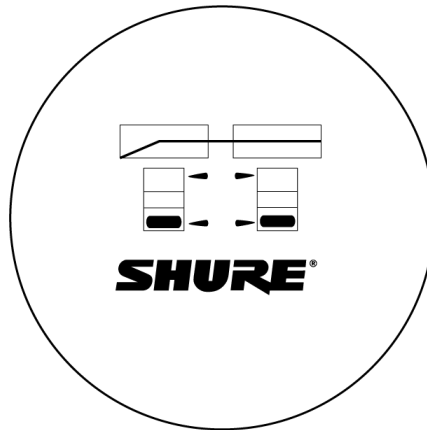

### Bass Rolloff

**Bass rolloff:** If you want to reduce the bass, push the left switch down. This can help lower background hum from A/C, HVAC, or traffic.





## Presence Boost

**Presence boost:** If you want a brighter sound in the mid-range frequencies, push the right switch up. This can help improve vocal clarity.

## Additional Tips

Visit [Shure Educational Articles](#) for more information on recording techniques for different instruments and applications.

---

## Additional Resources

- [Shure Knowledge Base FAQs](#)
- [Training from the Shure Audio Institute](#)
- [Microphone Techniques for Recording](#)
- [Houses of Worship Systems Guide](#)
- [Shure Performance & Production YouTube channel](#)
- [Shure Creators YouTube channel](#)

## Download Shure Software

- [Software and firmware archive](#)

---

## Specifications

### Type

Dynamic (moving coil)

### Frequency Response

50 to 20,000 Hz

### Polar Pattern

Cardioid

## Output Impedance

150  $\Omega$

## Sensitivity

(@ 1 kHz, open circuit voltage)

-59 dBV/Pa[1] (1.12 mV)

## Hum Pickup

(typical, at 60 Hz, equivalent SPL/mOe)

11 dB

## Polarity

Positive pressure on diaphragm produces positive voltage on pin 2 with respect to pin 3

## Net Weight

0.764 kg (1.69 lbs)

## Housing

Dark gray enamel aluminum and steel case with dark gray foam windscreen.

[1] 1 Pa=94 dB SPL

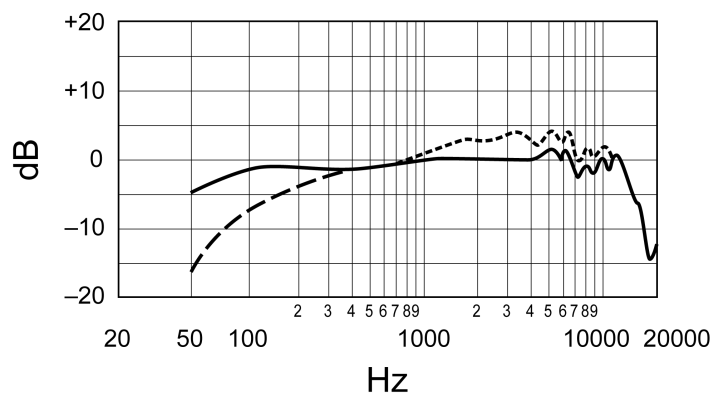

Flat Response

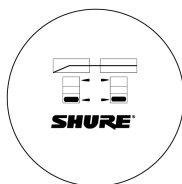

Bass Rolloff



Presence Boost

## Typical Frequency Response

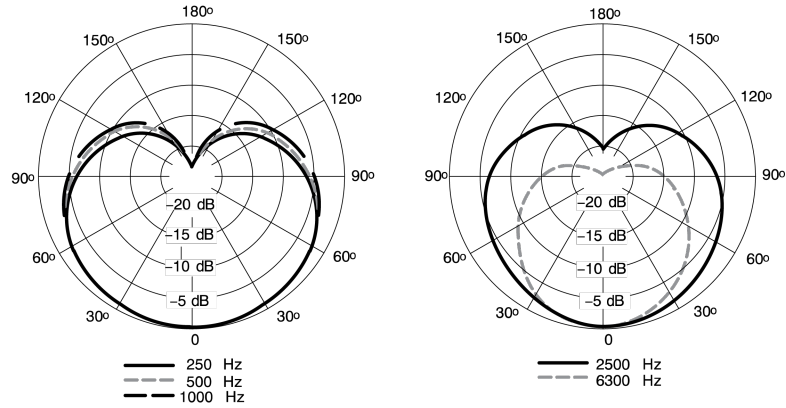

Typical Polar Pattern

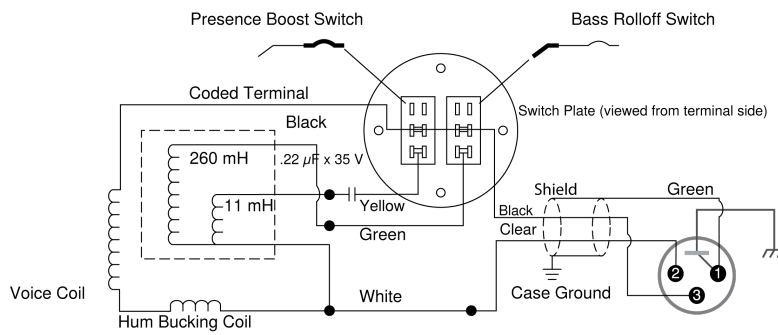

Internal Connections

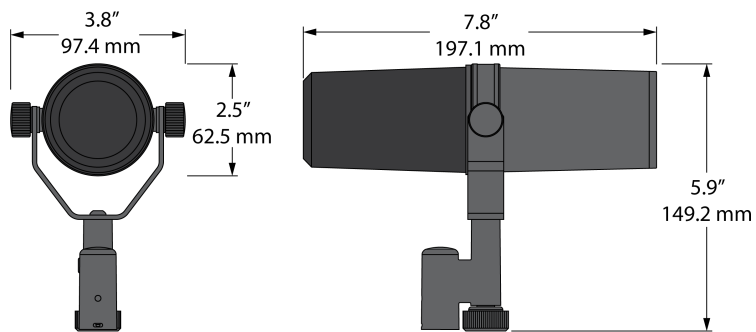

Overall Dimensions

# Accessories

## Furnished Accessories

Switch Cover Plate for SM7, SM7A and SM7B	RPM602
Large Black Foam Windscreen for SM7, also see RK345	A7WS
5/8" to 3/8" Thread Adapter	31A1856

## Optional Accessories

25 foot (7.5m) Triple-Flex <sup>®</sup> Microphone XLR Cable with chrome connectors	C25F
---	------

## Replacement Parts

Cartridge for SM7, SM7A and SM7B	RPM106
Black Windscreen for SM7, SM7A, SM7B, also see A7WS	RK345
Nut and Washer for SM7, SM7A and SM7B Yoke Mount	RPM604

# Certifications

## CE Notice

Hereby, Shure Incorporated declares that this product with CE Marking has been determined to be in compliance with European Union requirements.

The full text of the EU declaration of conformity is available at the following site: <https://www.shure.com/en-EU/support/declarations-of-conformity>.

## UKCA Notice:

Hereby, Shure Incorporated declares that this product with UKCA Marking has been determined to be in compliance with UK-CA requirements. The full text of the UK declaration of conformity is available at the following site: <https://www.shure.com/en-GB/support/declarations-of-conformity>.

### Authorized UK Importer / Representative:

Shure UK Limited  
Unit 2, The IO Centre, Lea Road,  
Waltham Abbey, Essex, EN9 1 AS, UK

## Waste Electrical and Electronic Equipment (WEEE) Directive



In the European Union and the United Kingdom, this label indicates that this product should not be disposed of with household waste. It should be deposited at an appropriate facility to enable recovery and recycling.

Please consider the environment, electric products and packaging are part of regional recycling schemes and do not belong to regular household waste.

---

## Registration, Evaluation, Authorization of Chemicals (REACH) Directive

REACH (Registration, Evaluation, Authorization of Chemicals) is the European Union (EU) and the United Kingdom (UK) chemical substances regulatory framework. Information on substances of very high concern contained in Shure products in a concentration above 0.1% weight over weight (w/w) is available upon request.