



## Graduate Certificate in Leadership

### **Good Leadership is in Demand in every Organization. Are you prepared for the Challenge?**

---

You may have many skills, but to be an effective manager today you need to provide your team with strong leadership. Today's leader must have vision and be a critical and strategic thinker. An effective leader is involved in policy formulation and organizational development. He/she must be able to implement innovative leadership practices to manage conflict and change in a dynamic global environment. This requires a good understanding of research methodology, social dynamics and strong communication skills which all contribute to developing and maintaining a successful organization.

A leadership education can be applied to every industry and organization where these skills are valued. If you need leadership skills which take you far beyond weekend seminars and on-the-job training, consider following a McGill Diploma in Management (Leadership concentration) or a Graduate Certificate in Leadership.

### **How can a McGill Program help you achieve your goals?**

---

The McGill Programs in Leadership are both student-oriented and professionally based. Student-oriented, because students participate with instructors in the design of the program and courses.

Professionally based, because the content of the programs are kept up to date with best practices in industry, and is frequently augmented by ongoing research.

You will learn:

- The latest leadership theories and concepts and how to apply them to your personal and professional life
- How to envision, plan, implement and evaluate leadership initiatives through different theories and models
- It will help you develop appropriate styles for communicating, influencing and handling conflict.
- Through group work, you will develop skills in empowering, delegating, teambuilding and leading positive change.

## The Program

---

The Graduate Certificate in Leadership program is a 15-credit graduate-level program that consists of consists of (one pre-requisite course,) four required three-credit courses and one three-credit complementary course.

Classes are offered once a week for 13 weeks and are generally from 6 p.m. to 9 p.m. Courses can be taken in the Fall, Winter, Spring and Summer sessions. Classes in the Spring and Summer sessions may be given in less than 13 weeks. Not all courses are offered every semester.

The certificate's program requirements are:

### **Pre-requisite to program<sup>1</sup>:**

CORG 551 Behaviour in Organizations  
(or the Exemption by Examination Test<sup>2</sup>)

### **4 Required courses (12 credits):**

CPL2 531 Leadership Theory and Practice  
CPL2 532 Leading Change  
CPL2 533 Developing Leadership Skills  
CPL2 534 Leading in Diverse and Global Workplaces

### **1 Complementary course from (3 credits):**

CCLW 511 Law 1  
CGM2 510 Project Management: Tools and Techniques  
CMIS 541 Information Systems for Managers  
CPL2 552 Strategic Management  
CPL2 553 Small Business Management  
CPL2 595 Topics in Leadership

Or any other 500 or 600 level course offered through Career and Professional Development and approved by the department.

### **IMPORTANT NOTE:**

This program is EFFECTIVE as of Fall 2009.

If you were admitted PRIOR to Fall 2009, please follow the STUDY PLAN which you were provided with at the time of your admission.

---

<sup>1</sup> Pre-requisite: CORG 551 is a pre-requisite to CPL2 531, CPL2 532, CPL2 533 and CPL2 552.

<sup>2</sup> For more information on how to obtain course exemption by the means of a challenge exam, please consult the Exemption by Examination form available on our website at:

<http://www.mcgill.ca/continuingstudies/prospective-students/apply/exemption-examination>.

# Course Sequence

## Graduate Certificate in Leadership

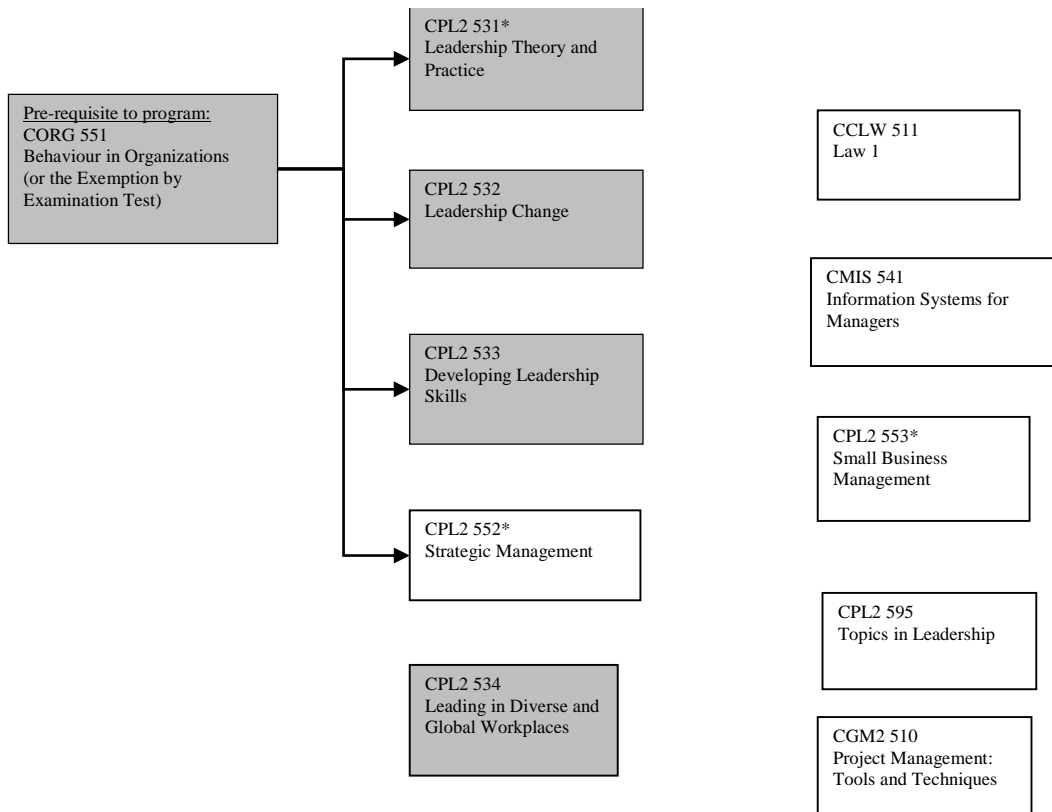

**NOTE:**

Required Course

Complementary Course

→ Pre-requisite to course

\*Please refer to course description for additional pre-requisite(s) to the course.

To obtain information on course offerings, please refer to the interactive timetable at [http://cce.mcgill.ca/timetable/GC\\_LDR\\_LDS.htm](http://cce.mcgill.ca/timetable/GC_LDR_LDS.htm).

## Course Descriptions

---

### **CCLW 511 Law 1**

**(3 credits)**

Pre-requisites:  
None

Sources and administration of law; the Canadian Constitution and the division of powers; the Quebec Civil Code, comprising the law of persons, the law of property, obligations, contracts, sale, lease and hire, mandate, suretyship, hypothecs and prescription.

### **CMG2 510 Project Management: Tools and Techniques**

**(3 credits)**

Pre-requisites:  
None

Focus on main concepts and theories of project management from initiation to close-out. Topics include: project life cycle, planning, scheduling, implementing, monitoring, controlling, close-out and ethics. The concepts presented apply to projects of various sizes, types and degrees of complexity.

### **CMIS 541 Information Systems for Managers**

**(3 credits)**

Pre-requisites:  
None

Introduces the importance of Information Systems (IS) in organizations and issues associated with managing these. Provides a strategic view of IS and Information Technology (IT). Students will be presented with managerial, informational and technological issues related to the management of IT, and with a framework to better manage them. Class discussions, case analysis, presentations.

### **CORG 551 Behaviour in Organizations**

**(3 credits)**

Pre-requisites:  
None

The implications for management and the essential concepts of social psychology such as motivation, perception, attitude change and organization. Group and organizational dynamics will be the major emphasis of the course. Classroom discussion and student participation is encouraged.

### **CPL2 531 Leadership Theory and Practice**

**(3 credits)**

Pre-requisites:  
Core program<sup>3</sup>

Leadership theory and practice, including a broad survey of leadership theories and the factors responsible for leadership effectiveness.

### **CPL2 532 Leading Change**

**(3 credits)**

Pre-requisite:  
CORG 551 Behaviour in Organizations

Leading and managing change issues, including the leader as a change agent and the change process itself. Various models of change and change leadership will be reviewed, as well as follower reluctance or resistance to change and strategies that leaders can use to gain follower commitment.

---

<sup>3</sup> Core Program: This refers to the successful completion of CACC 520 Accounting for Management, CFIN 512 Corporate Finance, CMS2 521 Applied Management Statistics, CMS2 542 Marketing Principles and Applications and CORG 551 Behaviour in Organizations.

**CPL2 533 Developing Leadership Skills****(3 credits)**

Pre-requisite:  
None

Role of leadership training and development in personal and organizational effectiveness. Assessing and developing personal leadership skills; developing leaders in organizational settings.

**CPL2 534 Leading in Diverse and Global Workplaces****(3 credits)**

Pre-requisites:  
None

Exploring leadership within a global and diverse context. A variety of trends that have made managing workforce diversity an essential competency for future leaders are reviewed, as are the emerging skills that managers need to develop to succeed in a global environment.

**CPL2 552 Strategic Management****(3 credits)**

Pre-requisites:  
Core program

Includes analysis of major forces driving organizations, explores mission development, goal selection, corporate strategy, policy formulation for the benefit of all stakeholders. Discusses situations confronting senior managers in the competitive environment, includes topics such as the identification and evaluation of strategic alternatives, the management of control processes for increased productivity, etc.

**CPL2 553 Small Business Management****(3 credits)**

Pre-requisites:  
CACC 520 Accounting for Management and CMR2 542 Marketing Principles and Applications

This course will focus on the concepts and activities of entrepreneurship in the small business environment. Through the analysis of small business situations and the study of related case material, students will learn the fundamental actions required in practice to start and manage a small business. Skill acquisition will be oriented toward learning to prepare a business plan.

**CPL2 595 Topics in Leadership****(3 credits)**

Pre-requisites:  
None

Specialized course covering advanced topics in Leadership area selected from current issues or themes in literature. (Content will vary from year to year).

## Admission Requirements

---

1. Bachelor's degree (or equivalent) as approved by the Graduate and Postdoctoral Studies Office, and have a minimum cumulative grade point average (CGPA) of 3.0/4.0 or a CGPA of 3.2/4.0 for the last two full-time academic years.
2. If your CGPA is lower than the above requirement, please submit the following for consideration with your application, official transcript.
  - a. **Letter of Intent:** A letter, 1 to 2 pages in length single-spaced, written in English or French, which addresses the following:
    - basis for interest in the program;
    - your knowledge that would be pertinent to the program;
    - your interest in the field of study and the reasons for applying to our program
    - plans for integrating the training into your current or future career;
    - a description of your professional experience and its relevance, if applicable, to the program
    - awards received or other contributions;
    - any additional information relevant to your application.
  - b. **Curriculum Vitae**
  - c. **Two Letters of Reference:** At least one should be from a current or former employer.
  - d. **GMAT and/or GRE Test Score Results (optional):** Submit a copy of the official test score results.

Note: Students with a Bachelor's degree other than commerce but wish to gain knowledge on the core management courses may enroll in a Diploma in Management (Leadership concentration) program. For more information, please visit: <http://www.mcgill.ca/continuingstudies/prospective-students/apply/graduate-programs%20>

# Admissions Procedures

---

## How to APPLY to the *Graduate Certificate in Leadership*?

Please follow the steps below:

### STEP 1:

- Go to <http://www.mcgill.ca/continuingstudies/>  
Click on “Apply”  
Click on “Graduate Programs”

### STEP 2:

**Verify** on the “**Apply for Admission to a Program**” page, the “Application Deadlines” for Canadian/Permanent Residents or International Students to ensure that you submit your application before the term deadline.

### STEP 3:

- **Review your Admission Requirements:** Once you have checked your application against all the requirements, you will be ready to apply to the program.
- Before you proceed you will need:  
A valid **email address** and a **credit card** (Visa, MasterCard or American Express).

### STEP 4:

- Once you are ready to apply online:  
Click on “**Click here now**” to bring you to the Application for Admission page.
- Click on the red bold “**Apply Now**” on the Application for Admission page.  
(Do **not** apply through “uApply” link).
- Fill in the login information on the “Admissions Login” page and the Biographical Information.
- On the “Apply for Admission” page, fill in the information requested.  
NOTE: When asked: “What are you applying for at McGill”, click on “Continuing Studies”
- Select the program you are applying to on the “Program Choice Selection” page.
- Continue to fill in the remainder of the application. (All sections to be completed are indicated in the textbox on the left hand side of the screen).

### STEP 5:

- Once you have applied online, you will receive a confirmation email providing you with a McGill ID number and a 6-character **PIN (Personal Identification Number)**.
- You will need to use this information to **log into MINERVA** ([www.mcgill.ca/minerva](http://www.mcgill.ca/minerva)) (McGill’s web-based information system for students) so that you can upload documents required for admission and follow-up on your status of your application.

## STEP 6:

- Once your application has been received and you have access to your Minerva account, you will be able to **upload your supporting documentation**, including a copy of transcripts. (A copy of your transcript with confirmation of degree awarded and date of graduation).
- Uploading your documents will speed up your application process and is strongly recommended.
- For instructions on how to proceed, please go to: [www.mcgill.ca/applying/submitting-your-documents/uploadingdocuments/](http://www.mcgill.ca/applying/submitting-your-documents/uploadingdocuments/)

(If you are unable to upload the documents, you can send them by regular mail or bring them in person to our Client Services office at the address above).

## STEP 7:

- **Sending official transcripts: All transcripts received via the upload process are considered unofficial.** If transcripts are required for your application, you will also need to have any official transcripts sent directly to the School by mail, in a sealed envelope by the educational institution(s) where you studied.

### What is an Official Transcript?

If you have studied at an institution:

- In Canada or the United States – you will need to request a copy of your official transcripts (your marks) from that institution which the institution will mail to the address below in a sealed envelope with the official institution's logo.
  - Outside of Canada or the United States, - you will need to request a copy of your official transcripts (your marks) from that institution which the institution will mail to the address below in a sealed envelope with the official institution's logo.
  - **Note:** In cases where the language of instruction at the institution is not English or French, you must also send an official translation of the official transcript certified by a representative from the **Ordre des traducteurs, terminologues et interprètes agréés du Québec (OTTIAQ)** - <http://ottiaq.org/> ).
- You need to request **official transcripts** as soon as possible once your application has been submitted to the School of Continuing Studies. Your Educational Institution must then mail these directly to the appropriate office below:

### Client Services c/o Admissions

McGill University – School of Continuing Studies  
688 Sherbrooke Street West, Room 1125  
Montreal, QC  
Canada, H3A 3R1



- **Important:** You must make sure you apply by the application deadline. However, if you have any outstanding supporting documents at the time of your application, you may upload them as they become available or forward them directly to the School of Continuing Studies as soon as possible. Your admission application will only be completed once the School has received all of the required documents.
- **Note:** All required documents received by McGill University School of Continuing Studies become the property of the university. Official documents and/or transcripts will not be returned to the applicant.
- **Note:** Transcripts received by McGill University's School of Continuing Studies cannot be transferred to any other department or program as it would constitute submitting a new application. Therefore, you must submit a new sealed envelope of your official transcripts for each application made to McGill University's School of Continuing Studies.

## Language Requirements

---

- The **language of instruction** for most courses and programs at McGill is English; however, students may submit any written work that is to be graded in English or French, except in cases where knowledge of the language is one of the objectives of the course.
- Applicants must demonstrate an adequate level of **proficiency in English prior to admission**, regardless of citizenship status or country of origin. McGill University has this language requirement in place to ensure that all students are provided with the opportunity to succeed in their chosen program.
- In all cases, the University reserves the right to require **proof of English** proficiency if it is deemed necessary. For additional information, please click on the link below.

<http://www.mcgill.ca/continuingstudies/current-students/academic-policies/language-policy>

## Exemption by Examination

---

Students admitted to a Certificate, Graduate Certificate or Diploma program requiring a pre-requisite or co-requisite course, must provide proof that they have taken an equivalent 3 credit course, at the appropriate level elsewhere or successfully completed the Exemption by Examination test. Otherwise the student must register for the course.

- Please note that the Exemption by Examination test is **not applicable to required or complementary course(s)** within a program.
- You cannot take the Exemption by Examination test if you have already attempted the course (a grade of W is considered as have attempted the course).
- If you are unsuccessful in the Exemption by Examination test(s) you will not be permitted to repeat the test(s) and must instead enroll in the course(s) for which the particular test(s) was taken.

**You must be admitted into a program or have applied to a program to be eligible to write the Exemption by Examination test.** (The test is optional).

For more information on how to obtain a course exemption by means of a challenge exam, please consult the Exemption by Examination form available on our website at:

<http://www.mcgill.ca/continuingstudies/prospective-students/apply/exemption-examination>

## **Student Awards and Financial Aid**

---

Note: The amount and number of McGill University's School of Continuing Studies Bursaries, Scholarships, and Graduating Prizes issued varies from year to year, depending on funds received and their specifications.

### **McGill University's School of Continuing Studies Bursaries**

The School of Continuing Studies will post the application form and eligibility requirements for the active term on its website. Please refer to link below for further information.

<http://www.mcgill.ca/continuingstudies/current-students/fees/student-awards-and-financial-aid>

### **McGill University's School of Continuing Studies Scholarships**

For a list of McGill Scholarships, please consult the McGill School of Continuing Studies website by clicking on the link below.

<http://www.mcgill.ca/continuingstudies/current-students/fees/student-awards-and-financial-aid>

### **McGill University's School of Continuing Studies Graduating Prizes**

For a list of McGill SCS Graduating Prizes, please consult the McGill School of Continuing Studies website by clicking on the link below.

<http://www.mcgill.ca/continuingstudies/current-students/graduating-students/awards>